



Estap Opensis workstations and computer room furnitures utilize open frame architecture with symmetrical, welded steel framework to provide effective workplace management. This frame work, coupled with a modular design concept, permits max. flexibility in workplace configuration, as well as the capacity to provide secure and enclosed environments. Additionally, Opensis allows a full compliment of user-specific, accessory solutions such as storage compartments, task lights and keyboard trays.

FEATURES

Workstation widths of 550mm., 1100mm., 1650mm., Symmetrically welded steel framework Integrated enclosures
Steel to steel connections
Laminated desktop, sheet steel shelves Tapped holes, on screw size
One tool for assembly
Vertical adjustability in 1" increments Front access to cable management Shelf weight capacities up to 300kg.

BENEFITS

Flexible, customized workspace configurations Easy to assemble and re-configure Adapts easily to changing workplace requirements Durable construction built for longevity Easy to configure and order Delivery from stock

STANDARDS

ISO 9001:2000

TSE:EN 61587-1 Mechanical Structures For Electronic Equipment - Tests For IEC 60917 And IEC 60297

Climatic and Environment: EN 61587-1/4.2, IEC60068-2-1, IEC60068-2-2, IEC60068-2-30,

Static Mechanical Load Lifting: EN61587-1/5.2.1

Static Mechanical Load Stiffness: EN61587-1/5.2.2

Dynamic Mechanical Load Vibration and Shock, Impact:

EN61587-1/5.3.1, EN61587-1/5.3.3, IEC60068-2-6, IEC60068-2-27,

Earth Bond: EN61587-1/6.2

Flammability: EN61587-1/6.3

Degrees Of Protection Provided By Enclosures (Ip Code):

IP20 or IP55, EN61587-1/6.4

COMPLIANCES

UL and cUL

Surface Treatment: Fosfat coating

Painting: Ral7035 / Ral9005

TECHNICAL DRAWINGS



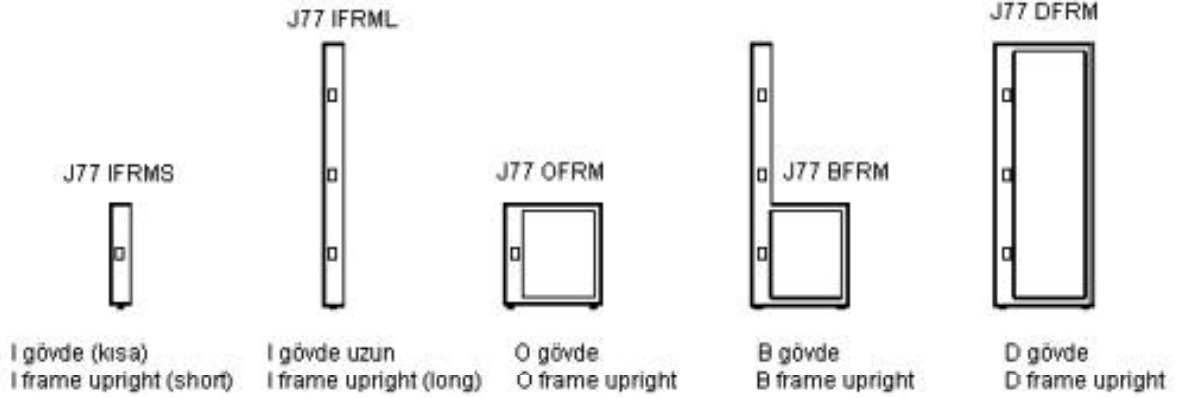

FEATURES

Unique welded steel frame
Adjustable in 1" increments
Weight capacity 500kg.
Horizontal cable pass through
Nylon levelling glides stand art
Optional casters available

A minimum of two (2) back braces are required to support two frame uprights. Vertical cable runs inside frame uprights are not recommended. It is suitable to vertical cable management

Frame Upright	
Order No	Product Definition
J77 O FRM	O frame uprights d=725mm h=780mm
J77 B FRM	B frame uprights d=725mm h=1950mm
J77 D FRM	D frame uprights d=725mm h=1950mm
J77 I FRML	I frame uprights (long) d=155mm h=1950mm
J77 I FRMS	I frame uprights (short) d=155mm h=780mm

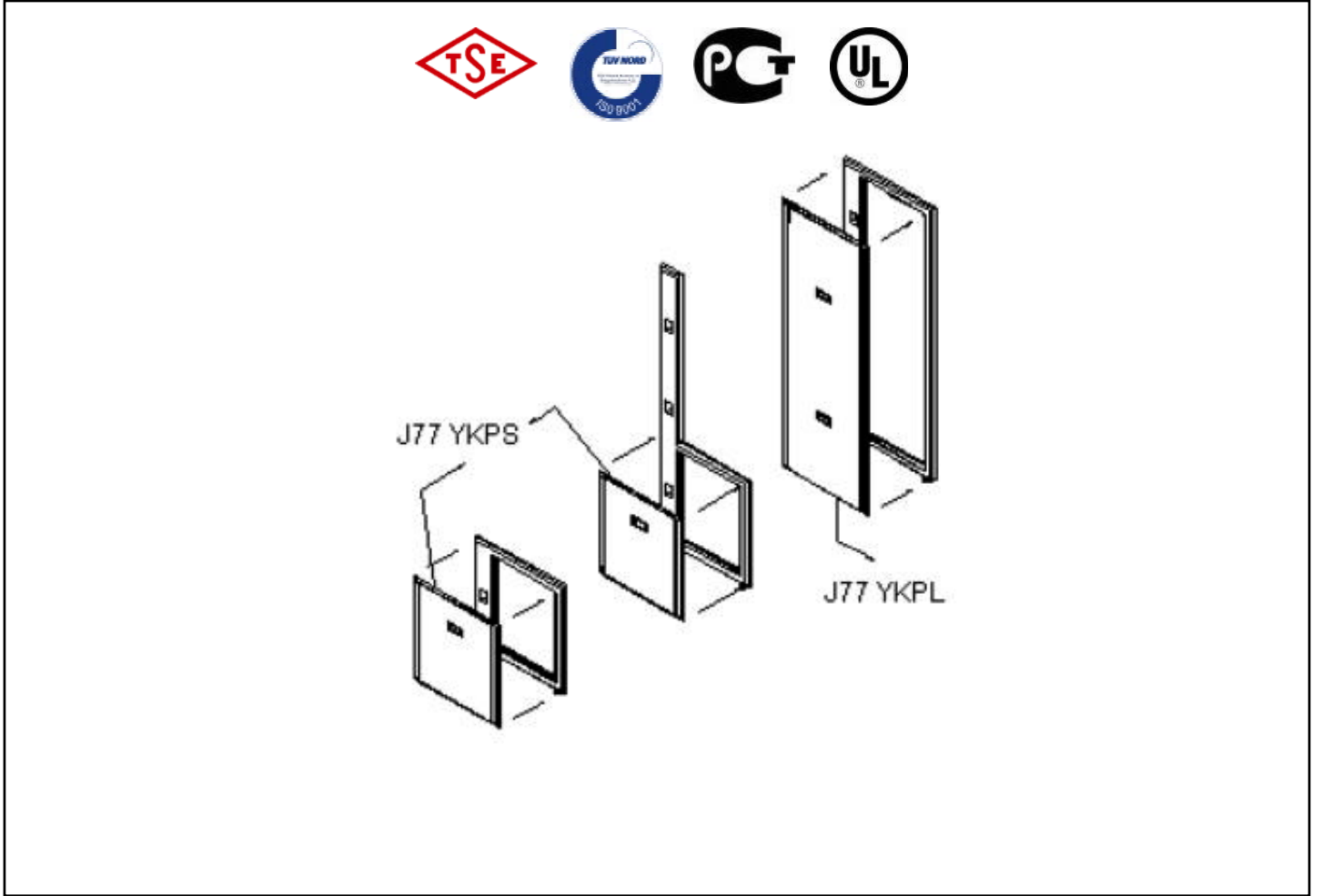

Side Panels	
Order No	Product Definition
J77 YKP S	side panel S h=720mm w=680mm
J77 YKP L	side panel L h=1890mm w=680mm



FEATURES

Two back braces are required to support two frame uprights. Back panels and braces are in same dimensions. Enough back panel or braces are necessary to enclose back side of workstation.

Back Panels And Braces	
Order No	Product Definition
J77 AKP W1	Back panel and brace w=575mm h=270mm
J77 AKP W2	Back panel and brace w=1125mm h=270mm
J77 AKP W3	Back panel and brace w=1675mm h=270mm
J77 AKP W4	Back panel and brace w=575mm h=4500mm
J77 AKP W5	Back panel and brace w=1125mm h=450mm
J77 AKP W6	Back panel and brace w=1675mm h=450mm

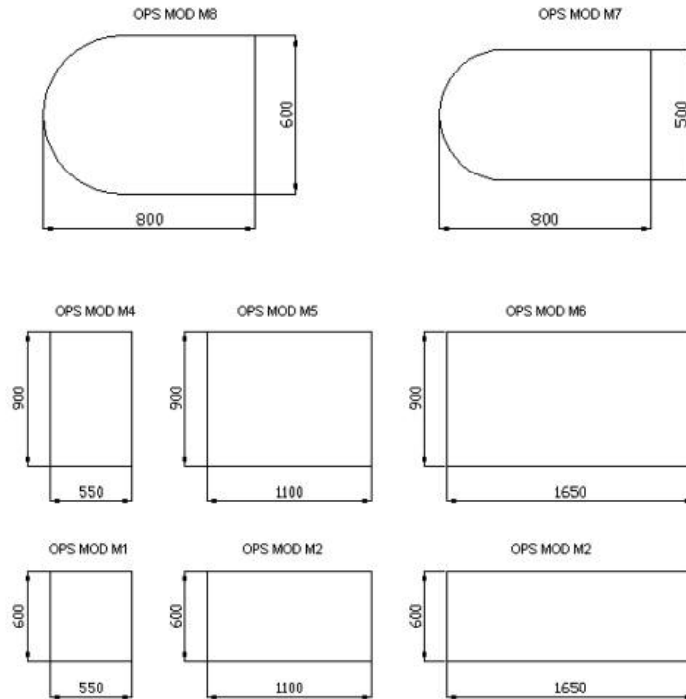

FEATURES

It's designed as work surfaces. Material is wood and covered by laminant. Thickness is 30mm.

Work Surfaces	
Order No	Product Definition
OPS MOD M1	Laminated work surface t=30mm w=550 mm d=600 mm
OPS MOD M2	Laminated work surface t=30mm w=1100 mm d=600 mm
OPS MOD M3	Laminated work surface t=30mm w=1650 mm d=600 mm
OPS MOD M4	Laminated work surface t=30mm w=550 mm d=900 mm
OPS MOD M5	Laminated work surface t=30mm w=1100 mm d=900 mm
OPS MOD M6	Laminated work surface t=30mm w=1650 mm d=900 mm
OPS MOD M7	Laminated work surface t=30mm w=800 mm d=500 mm
OPS MOD M8	Laminated work surface t=30mm w=800 mm d=600 mm

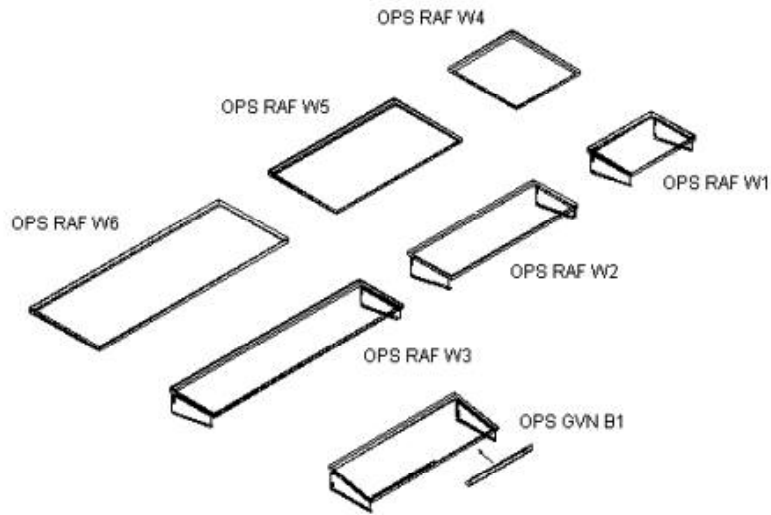

FEATURES

It's designed for PC, server, screen and other active devices organisation. It could be mounted angular position. At angular position anti-slide brackets must be used.

Material is sheet steel and welded. Weight capacity is w=150kg.

Shelves	
Order No	Product Definition
OPS RAF W1	shelf w=550mm d=380mm
OPS RAF W2	shelf w=1100mm d=380mm
OPS RAF W3	shelf w=1650mm d=380mm
OPS RAF W4	shelf w=550mm d=600mm
OPS RAF W5	shelf w=1100mm d=600mm
OPS RAF W6	shelf w=1650mm d=600mm
OPS GVN B1	anti - slide bracket

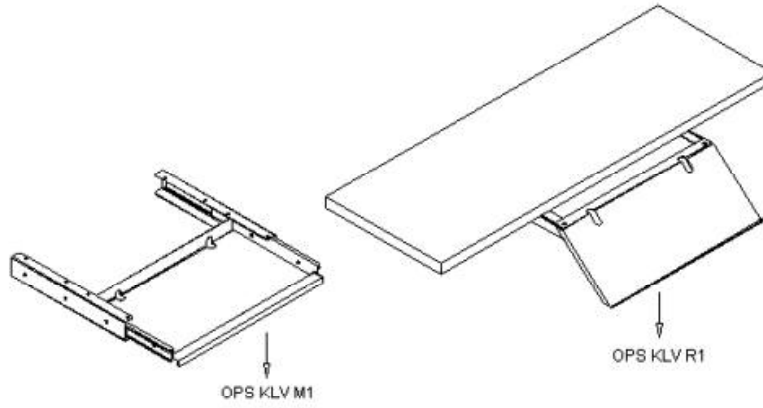

FEATURES

It's designed for worksurfaces and shelves as 2 (two) type. Material is sheet steel and welded.

Keyboard Trays	
Order No	Product Definition
OPS KLV M1	Keyboard tray for work surface w=510mm d=380mm
J77 YKP L	Keyboard tray for shelf

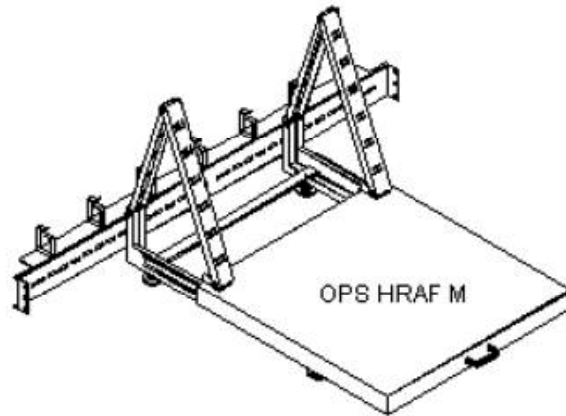

FEATURES

It's designed for PC, server and other active device organisation. It IS heavy duty tIpe. Sliding rail open 52cm. It is used with back cable management. Material is sheet steel and welded. Weight capacity is w=150kg.

Sliding Shelves	
Order No	Product Definition
OPS HRAF M	Sliding shelf complete with cable management and brackets w=550 mm d=600 mm

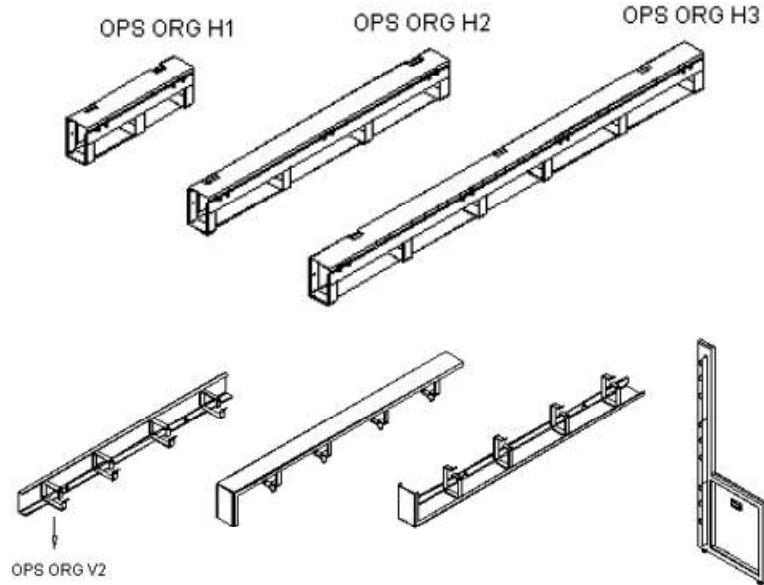

FEATURES

HORIZONTAL CABLE MANAGEMENT:

Easy access and organisation of cables.
Used rear of worksurfaces and shelves.
Paver strips can be mounted in cable management.

VERTICAL CABLE MANAGEMENT:

It's standard dimensions and used vertical cable organization. Enough vertical cable management modules are necessary for full height of upright frames.

Cable Management	
Order No	Product Definition
OPS ORG H1	Horizontal cable management w=450 mm
OPS ORG H2	Horizontal cable management w=1000 mm
OPS ORG H3	Horizontal cable management w=1550 mm
OPS ORG V2	Horizontal cable management h=590 mm

Opensis / Locable Storage Compartments



FEATURES

OVERHEAD TYPE:

It's designed for storage and has optional compartments. The front door is lockable. Material is sheet steel and welded. Weight capacity is w= 1 00kg.

UNDER WORKSURFACE TYPE:

It has 3(three) compartment. Use for general purposes. It is lockable has casters. Body welded and sheet steel.

Locable Storage Compartments	
Order No	Product Definition
OPS UDP W1	Lockable overhead storage compartments w=550 mm d=380 mm
OPS UDP W2	Lockable overhead storage compartments w=1100 mm d=380 mm
OPS UDP W3	Lockable overhead storage compartments w=1650 mm d=380 mm
OPS ADP W1	Under worksurface storage

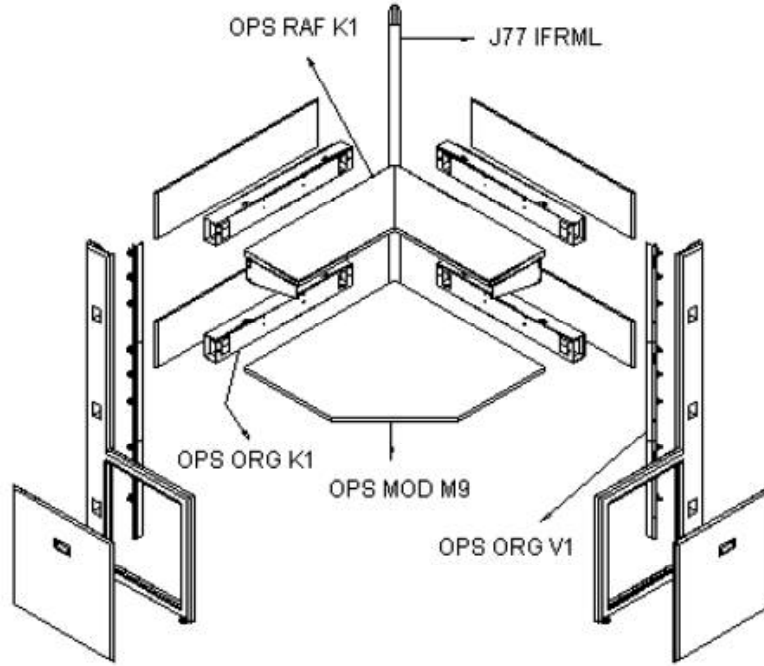

FEATURES

CORNER SHELF:

It's modular structure and easy to mount upright frames. Welded and sheet steel. Weight capacity w= 150kg.

CORNER WORK SURFACE:

Laminated worksurface t=30mm. Weight capacity w=250kg.

CORNER CABLE MANAGEMENT:

Easy access and organisation of cables. Used rear of worksurfaces and shelves. Power strips can be mounted in cable management. I (long) or i (short) upright frames are used constitute corner group. It's connected by braces to adjacent upright frame. Standart vertical cable management modules can be used for cabo organisation. Corner group provides effective technical workspace management.

Corner Group	
Order No	Product Definition
J77 I FRML	I frame upright (long) d=150 mm h=1950 mm
J77 I FRMS	I frame upright (short) d=150 mm h=780 mm
OPS RAF K1	corner shelf w=1000 mm d=380 mm
OPS MODM9	corner worksurface w=1000 mm d=1000mm
OPS ORG K1	corner cable management
OPS ORG V1	corner cable management h=900 mm
J77 AKP W2	back panel and brace w=1125 mm h=270 mm